

APC AMERICAN PRECAST CONCRETE, INC.

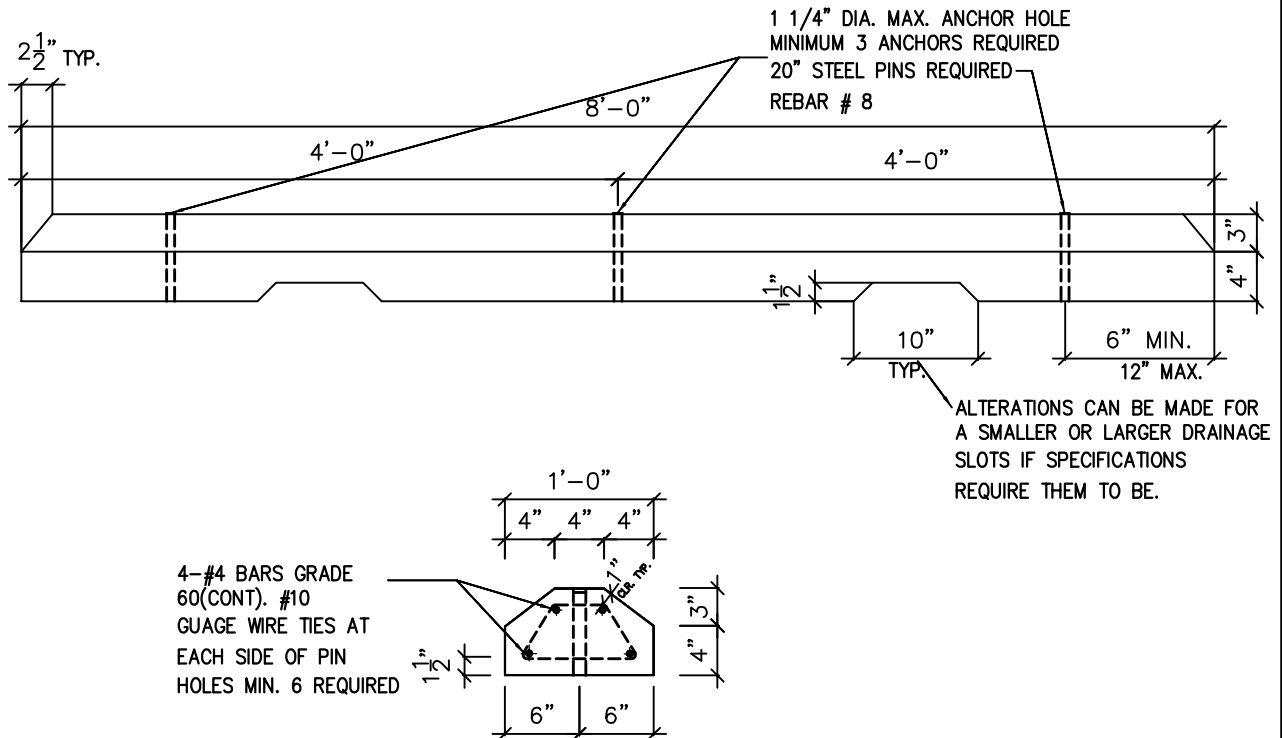

1 8' PRECAST CONCRETE WHELL STOP
ST7|ST8 SCALE: N.T.S.

NOTE:

PORTLAND CEMENT CONCRETE SHALL BE A,
SIX SACK MIX. DEVELOPING NOTHING LESS
THAN 5000 PSI COMPRESSIVE STRENGTH
AT 28 DAYS.

FACTORY: 2246 N. DURFEE AVE. EL MONTE, CA. 91732
TEL. (626) 443-0970 FAX (818) 827-4941
WEB: WWW. APC WHEELSTOPS.COM